

Rotary Indexers

QVI Rotary Indexers allow automatic part rotation to present features to available sensors at set angles for subsequent measurement.

- QVI 3D metrology software provides complete control of single or dual rotary indexers, and can rotate the part coordinate reference system in 3D space as the part is indexed
- Moment load capacity up to 30 kg-cm
- A variety of standard chucks and collets are available, as well as custom workholding fixtures
- A wide range of rotary indexer configurations to fit a variety of applications, from simple turned parts to complex-shaped parts such as turbine blades and vanes

Single and Dual Indexers for 4th & 5th Axis Measurements

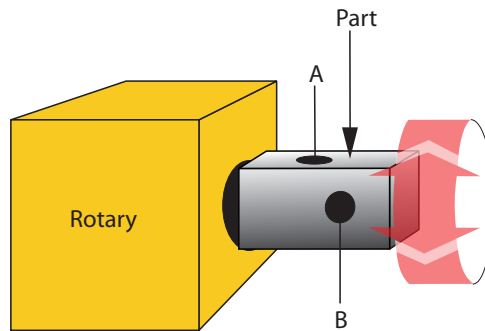

Single Rotary - Measure holes A and B with optical-axis sensors by rotating the part 90°.

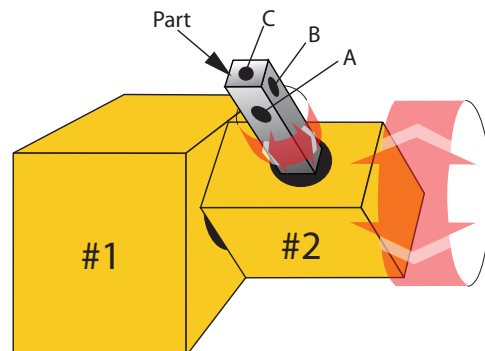

Dual Rotaries - Part with holes A,B,C on separate surfaces.

- Rotate rotary #1 until part is horizontal.
- Rotate #2 to measure A.
- Rotate #2 90° to measure B.
- Rotate #1 until part is vertical to measure C.



Single-Axis Rotaries (4th Axis)

Single-axis rotary indexers are programmable angular positioning devices that allow automatic indexing of parts. A range of models are available, offering a variety of moment load capacities and levels of rotational resolution

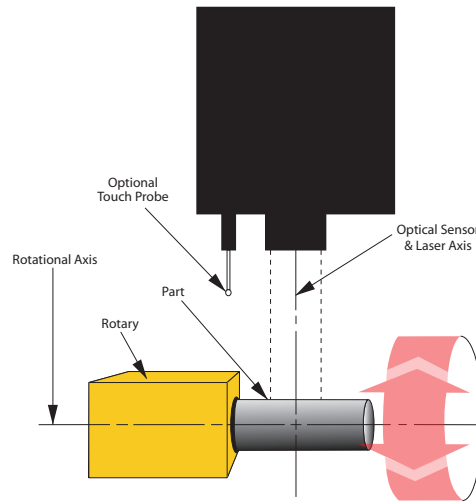

Single-Axis Rotary

Typical mounting configuration of a single rotary with its rotational axis perpendicular to the measurement system's optical axis, and parallel to the X- or Y-axis.

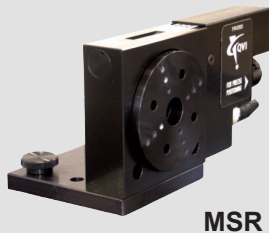

MSR

Miniature Servo Rotary (MSR™)

The Miniature Servo Rotary is an economical, light duty indexer ideal for measuring parts in multiple views under automatic program control. It is designed for use with any QVI measurement system.

The mounting bracket of the MSR allows horizontal or vertical axis applications. With a rotational resolution of 16 seconds of arc, the MSR is ideal for measuring screw machine parts, precision hydraulics and other turned or cylindrical parts. It is also ideal for measuring multiple views of prismatic parts in a single setup.



MTR

MicroTheta™ Rotary (MTR)

The MicroTheta Rotary is a high-accuracy rotary indexer with twin reader heads for ultimate positional resolution with double the load capacity of the MSR.

The MTR produces 720,000 counts per revolution of the spindle per reading head, for angular position resolution greater than 2 seconds of arc.

With its closed loop feedback system, the MTR makes angular measurements to within ± 5 arc seconds. The MTR's resolution and feedback allow for relational measurements between rotations.

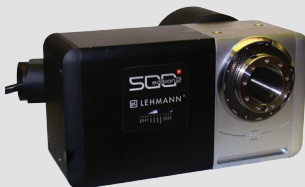

HDR

Heavy Duty Rotary (HDR)

The Heavy Duty Rotary is designed for holding heavy parts on a floor model QVI measurement system.

With a resolution of 3.6 seconds of arc and an accuracy rating of ± 5 arc seconds, the HDR is an excellent choice for larger parts or to support a dual rotary combination, allowing a fifth measurement axis. It can carry loads up to 30 kg-cm.

The HDR combines high load capacity with high precision angular positioning in a rotary indexing system designed for demanding industrial applications.



HPR

High Precision Rotary (HPR)

The High Precision Rotary provides high accuracy air-bearing fourth axis measuring. Its air bearing spindle, DC servo motor, and precision ruled rotary encoder provide the accuracy required to measure angular displacement between features.

The HPR may be mounted either horizontally or vertically. Its high speed and rigid body behavior allows 360 degrees of rotation in less than 8 seconds. It is ideal for the most demanding measurements that require the highest precision. It has an accuracy of ± 1 arc second.

Dual Rotary

Rotary #1 rotates Rotary #2, which holds the part under test. Adjusting the positions of both #1 and #2 allows the surfaces of complex parts like turbine blades to be presented perpendicular to the optical axis along their entire path. Note: The size of the part limits the usable range of Rotary #1 during a measurement.

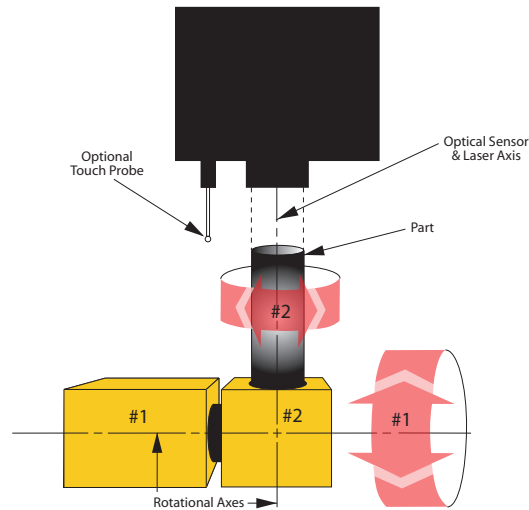

Miniature Servo Rotary/Miniature Servo Rotary (MSR/MSR)

Combine two Miniature Servo Rotary indexers to provide rotary motion in two perpendicular axes.

An MSR/MSR configuration is a cost-effective yet capable way to provide measurement flexibility for measuring multiple views of lightweight parts.

MicroTheta Rotary/Miniature Servo Rotary (MTR/MSR)

Combine MicroTheta Rotary and Miniature Servo Rotary indexers on a benchtop measuring machine to provide rotary motions in two perpendicular axes.

The MTR is used as the primary rotary in this configuration, making this setup ideal for positioning complex, lightweight parts into separate views.

Heavy Duty Rotary/MicroTheta Rotary (HDR/MTR)

Using Heavy Duty Rotary and MicroTheta Rotary indexers during a measurement routine allows for the rotation of parts into view with higher accuracy.

The HDR is used as the primary rotary in a configuration that allows for complex measurements on small parts. This popular combination offers rotational positioning accuracy to ± 5 arc seconds for part loading of up to 8 kg-cm.

Use the combination of Heavy Duty Rotary and MicroTheta Rotary for more challenging, high precision measurement requirements that require a 3D datum structure and relationships between rotations.

Dual Heavy Duty Rotary (HDR/HDR)

The dual Heavy Duty Rotary configuration has a 30 kg-cm load capacity, allowing for rotation of larger parts.

With a high rotational positioning accuracy of ± 5 arc seconds, dual HDRs can rotate heavy parts while maintaining optimum positional accuracy.

The dual HDR is a premium dual rotary, ready to handle the most challenging industrial applications.

Dual-Axis Rotaries (4th and 5th Axis)

Mount two rotary indexers together with their axes perpendicular to one another to add two axes of part positioning. The part under inspection is attached to the secondary rotary, which is mounted to the primary rotary. The part can be rotated in two different axes to bring features with compound angles into line of sight of the optical sensor axis, and within reach of measuring laser sensors or touch probes.

Several combinations of rotaries are configurable, depending on the application and the machine's available measurement envelope.

3D-capable QVI metrology software fully supports the simultaneous rotation of two rotaries.

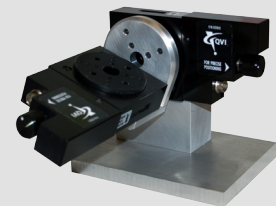

MSR/MSR



MTR/MSR



HDR/MTR

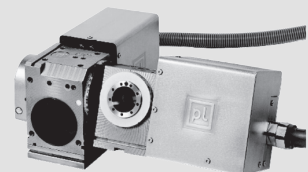

HDR/HDR

Rotary Indexers

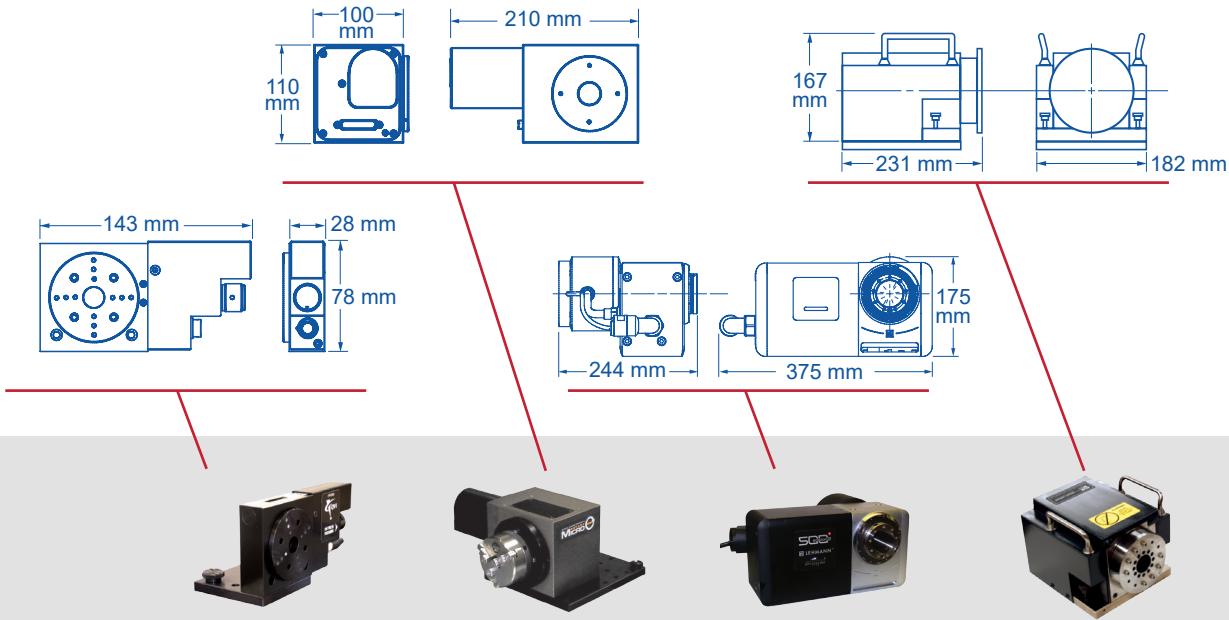

Technical Specifications

	Miniature Servo Rotary (MSR) (PN 525491)	MicroTheta Rotary (MTR) (PN 525986)	Heavy Duty Rotary (HDR) ¹ (PN 531831)	High Precision Rotary (HPR) (PN 310550)
Dimension (LWH, not including rotary base)	143 x 28 x 78 mm	210 x 100 x 110 mm	375 x 244 x 175 mm	231 x 182 x 167 mm
Spindle centerline to worktable (when axis is in XY plane)	46 mm	66 mm	110 mm	95 mm
Faceplate diameter	61 mm	85 mm	70 mm	106 mm
Resolution²	16 seconds of arc	2 seconds of arc	3.6 seconds of arc	0.9 seconds of arc
Accuracy²	± 2 arc min	± 5 arc sec	± 5 arc sec	± 1 arc sec
On-axis moment load capacity	4.0 kg-cm	8.0 kg-cm	30 kg-cm (± 0-30°) 15 kg-cm (± 30-90°)	11.4 kg-cm
Off-axis moment load capacity³	2.0 kg-cm	4.0 kg-cm	15 kg-cm (± 0-30°) 7.5 kg-cm (± 30-90°)	10.0 kg-cm

¹Available only for fixed granite bridge design, floor model QVI systems.

²Repeatability and accuracy specifications with off-axis faceplate loading may be greater than standard specifications.

³With symmetrically distributed load.

Contact QVI for specifications for dual rotaries.

Contact QVI concerning which rotaries are supported by particular QVI measurement systems.



Phone: (585) 544-0400 • (800) 647-4243
 Fax: (585) 544-8092
 info@ogpnet.com
 www.ogpnet.com

